

PETKIT™

USER MANUAL

PETKIT EVERSWEET ULTRA AI HEALTH CARE
PET WATER FOUNTAIN

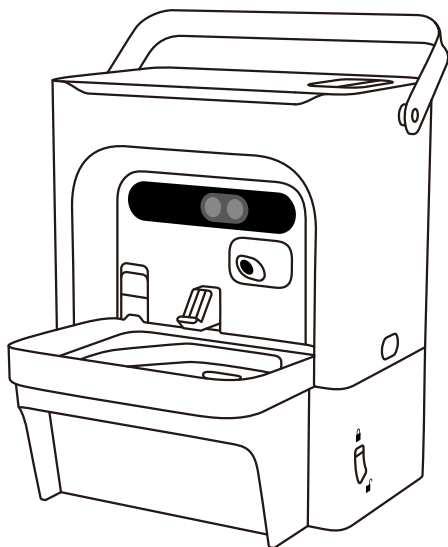

Please read the user manual carefully before using the product and keep it properly for future reference.

CONTENTS

PACKAGE LIST	3
PRODUCT INTRODUCTION	4
INSTALLATION GUIDE	6
USAGE GUIDE	9
SOFTWARE FEATURES	11
CONTROL PANEL & INDICATOR LIGHT	23
VIDEO GUIDE	26
BASIC SPECIFICATIONS	26
TO OUR VALUED USERS	27
SAFETY INSTRUCTIONS	27

01 PACKAGE LIST

* The product undergoes strict water injection testing before leaving the factory, which may result in slight residual moisture inside the unit. This is a normal occurrence.

Preparation

1. Remove all accessories from the packaging and peel off the protective tapes.
2. Check the items against the product list to ensure everything is included.
3. Before installation, please clean the Clean Water Tank, Waste Water Tank, and Water Tray.

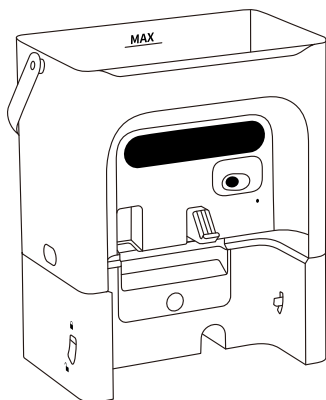

Clean Water Tank & Base

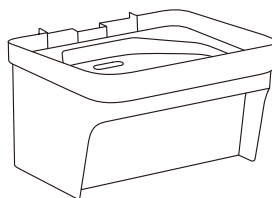

Waste Water Tank



Clean Water Tank Lid

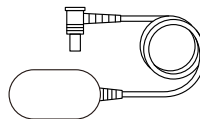

Power Adapter



Fountain Cube



2-in-1 Cleaning Brush

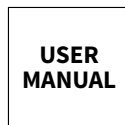

User Manual

02 PRODUCT INTRODUCTION

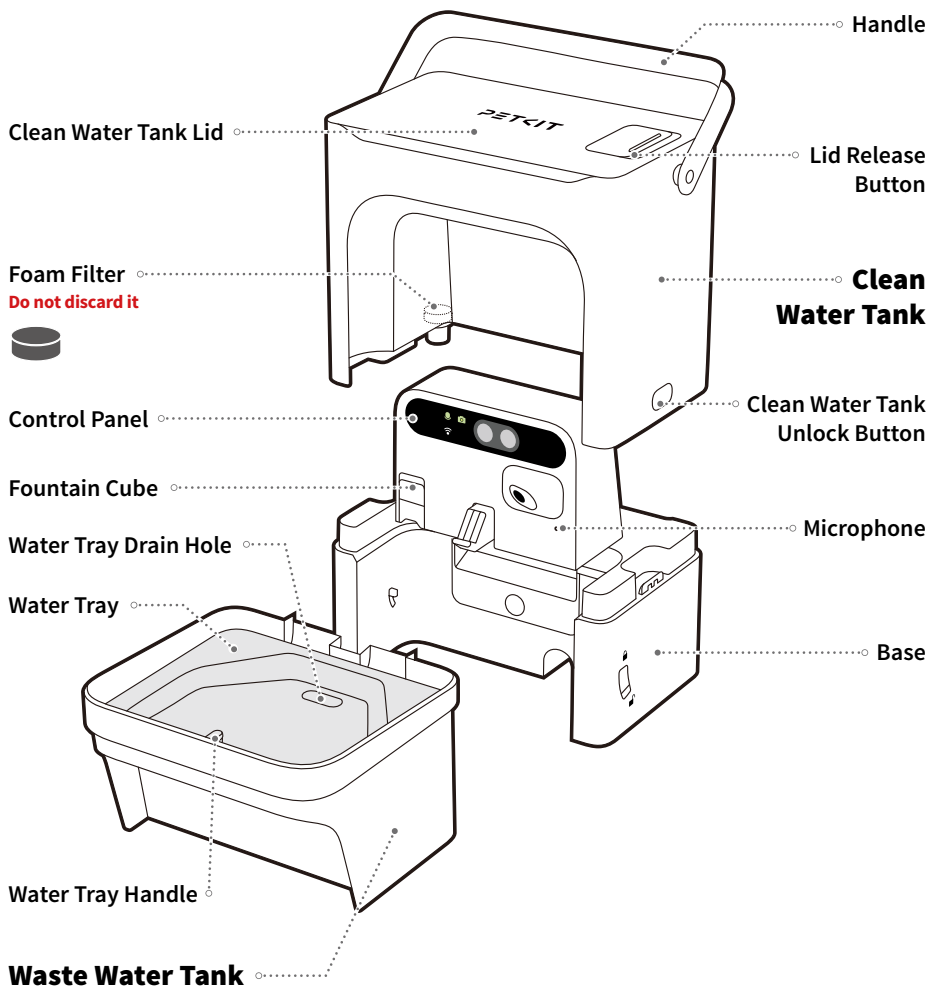

* Due to continuous product improvements, there may be slight differences in the actual product (including but not limited to appearance, structure, and color). The product images displayed on packaging and promotional materials are for reference only.

Front Side of Base

Fountain Cube
self-installation needed

FlowLift Module

Fountain Outlet

Water Pump
non-removable (Only the
internal impeller cover and
impeller are removable)

Magnetic Strainer
Pull the handle down to
detach it.

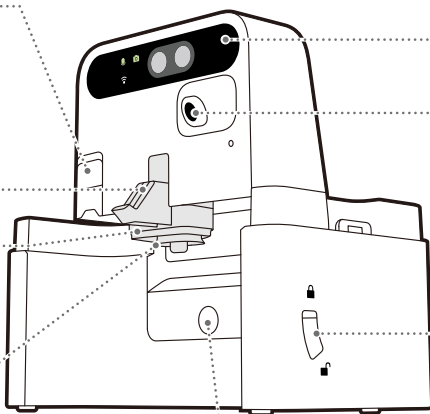

Control Panel

Camera
non-removable

Waste
Water Tank
Unlock Button

Waste Water Tank
Full Indicator Light

⚠ Do not force the Fountain
Outlet by hand.

Back Side of Base

Waste Water Tank
Unlock Button

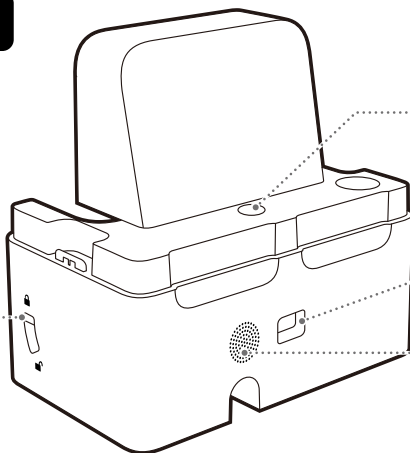

Water Shortage
Indicator Light

Power Port

Speaker

⚠ The internal part of the base contains components.
Do not rinse or soak it; only wipe it clean.

03 INSTALLATION GUIDE

3.1 Installing the Fountain Cube

Insert the Fountain Cube into the designated slot on the main unit, making sure it is pressed fully into place.

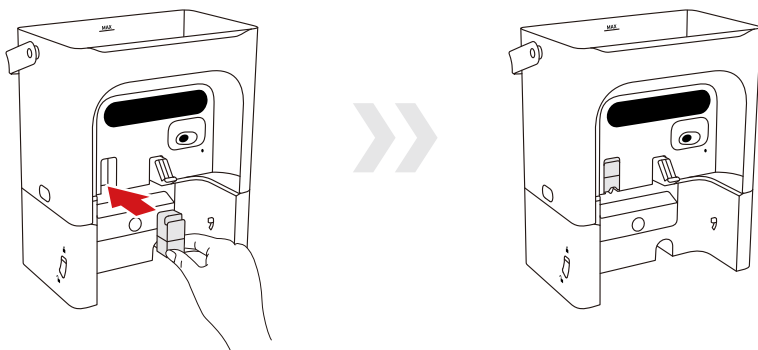

3.2 Installing the Waste Water Tank

Install the Waste Water Tank into the Base. A "click" sound indicates it is properly installed. (The Waste Water Tank Unlock Button will pop up automatically.)

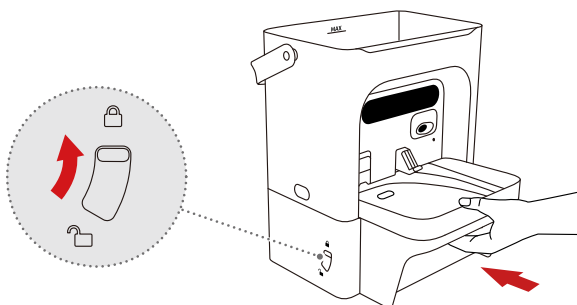

3.3 Filling the Clean Water Tank

This product offers two ways to fill the clean water tank. You can choose the method that suits your habit. We recommend using purified water or drinking water.

Method 1

Pour purified water into the Clean Water Tank until it reaches the MAX line, then install the Clean Water Tank Lid.

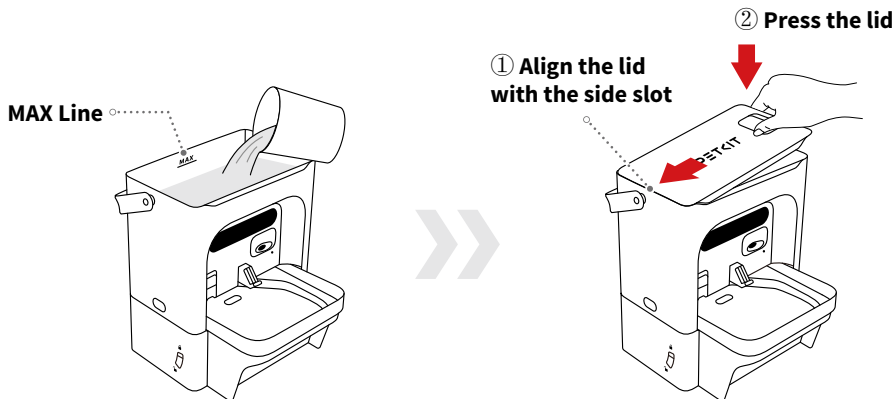

Method 2

1 Press the unlock buttons on both sides simultaneously, lift the tank, and fill it up to the MAX line.

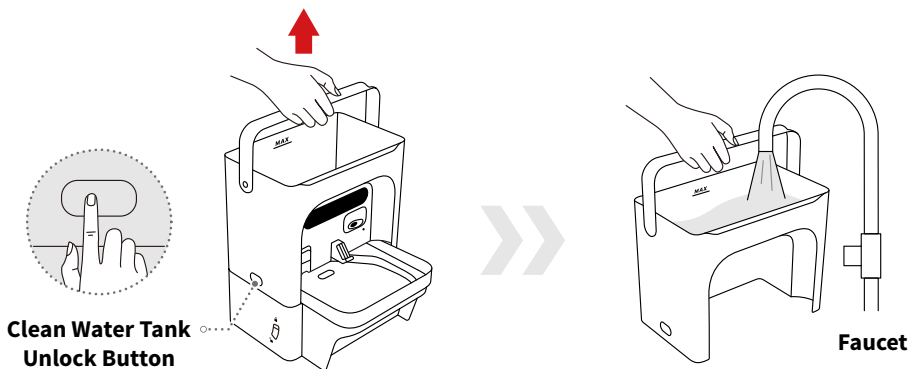

② Reinstall the tank. A "click" sound indicates it is properly installed. Then install the lid.

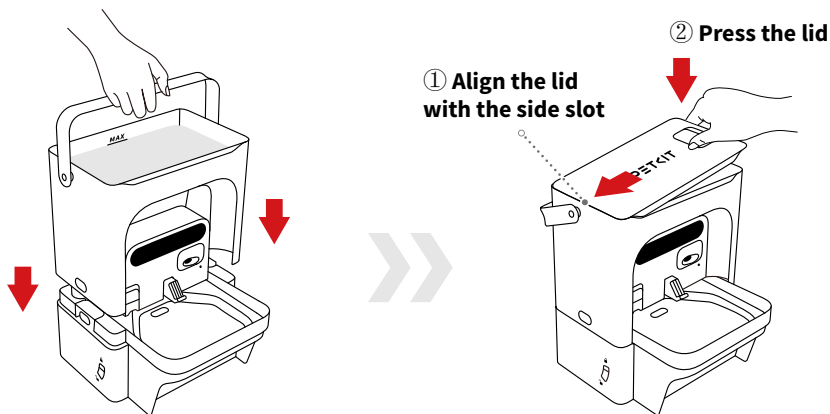

3.4 Connecting the Power Supply

Insert the power cord into the power port of the device and connect the power supply.

⚠ For first-time use, the device must be paired with the app before water can dispense.

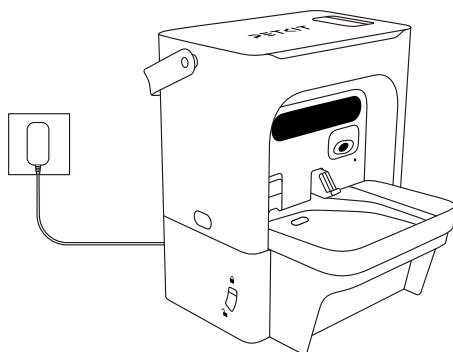

04 USAGE GUIDE

4.1 App Pairing and Activation

 [Note] For first-time use, you must pair the device with the App. After successful pairing, the device is ready for normal operation.

1 Download and install the App

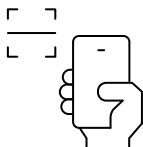

Download the PETKIT App from the App Store or Google Play.

2 Add device

Open the PETKIT App. Tap "+" to start adding a device. Select "EVERSWEET ULTRA AI".

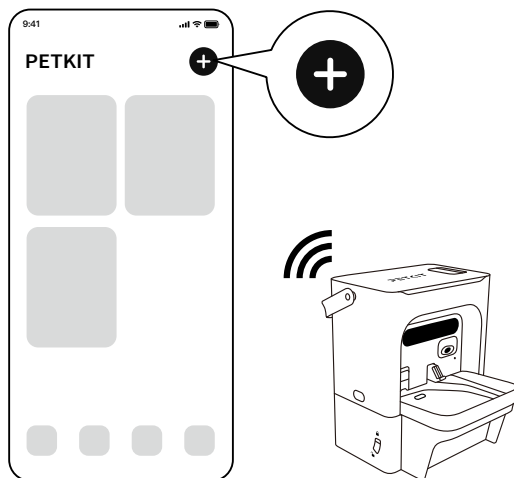

3 Start Pairing

Follow the on-screen instructions to pair. When the Wi-Fi indicator light on the device flashes white quickly, it means the App is attempting to connect to the device. Please wait until the connection is successfully established.

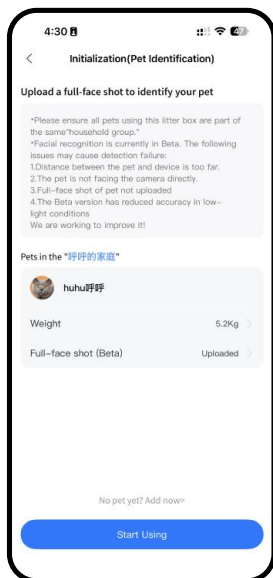
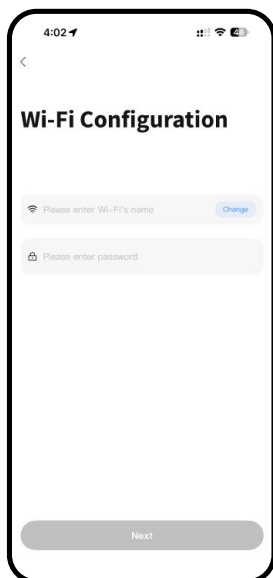
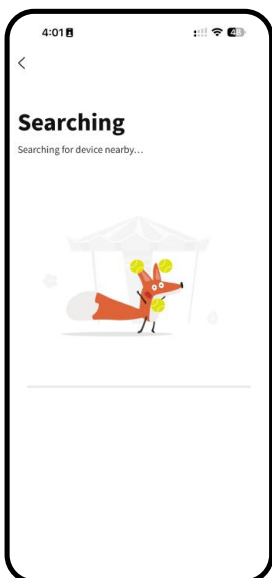
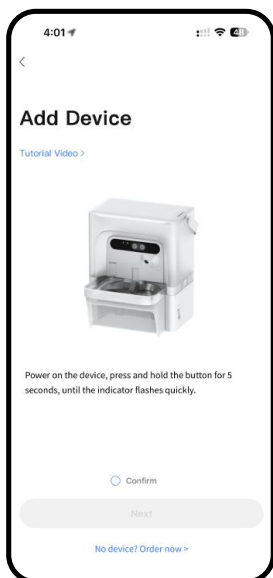

* Note: Interface may vary due to irregular software updates, please refer to the actual one.

05 SOFTWARE FEATURES

5.1 Device Home Page

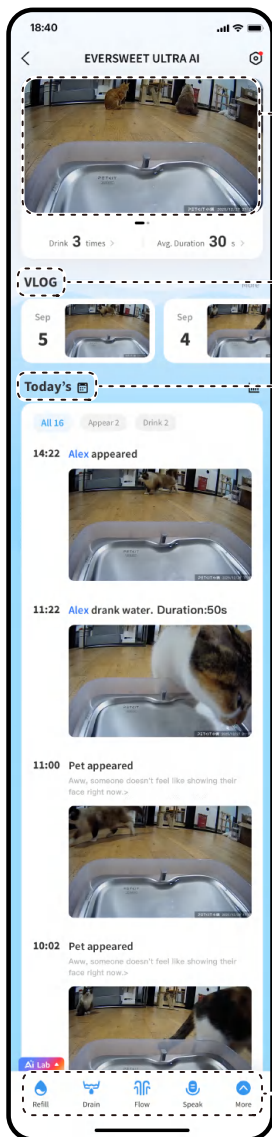

1 Live View Area

View real-time footage to check on your pet

2 VLOG

The system automatically generates a highlight reel of your pet's activities from the previous day every day at 8:00 AM. This section displays highlight videos from the last 7 days.

3 Today's Activity

Using AI algorithms, detected events are categorized into Appear, Drink. You can select specific events to view.

* Without a PETKIT Care+ subscription, only event images are available. To access features like full video playback, highlight playback, and speed-up playback, please subscribe to the PETKIT Care+ plan. For specific terms, please refer to the "PETKIT Care+ Service Agreement".

4 Function Buttons

Tap the "More" button to access additional functions.

5.2 Device Dashboard

Swipe left to enter the Device Dashboard. The Dashboard displays the status of the water tanks and the Fountain Cube.

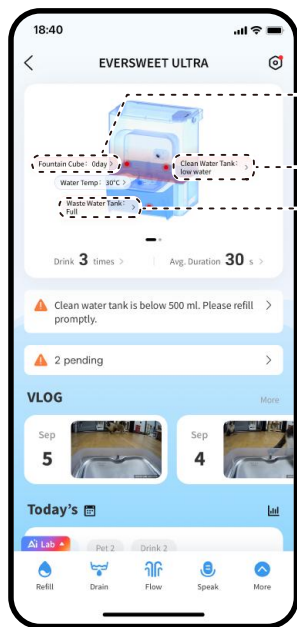
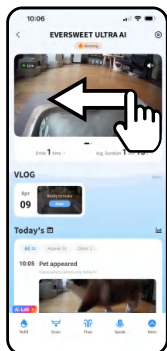

① Replace Fountain Cube

- ▶ When the Fountain Cube label turns red and shows "0 days", replace it immediately. After installing a new Fountain Cube, tap "Reset". When "30 days" is displayed, the installation is complete.

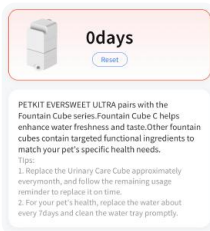

② Refill Clean Water Tank

- ▶ When the Fresh Water Tank label turns red, it means the fresh water is almost depleted. Please refill promptly.



③ Empty Waste Water Tank

- ▶ When the Waste Water Tank label turns red, it means the tank is full. Please empty it immediately.



5.3 Function Buttons

5.3.1 Add Water

Tap the "Refill" button to add water to the water tray.

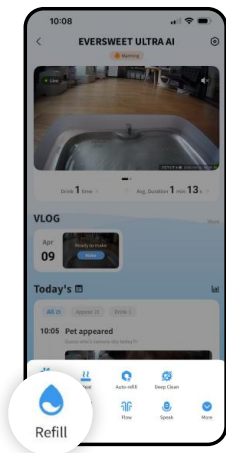

5.3.2 Drain

Tap the "Drain" button to drain the residual water from the water tray into the waste water tank.

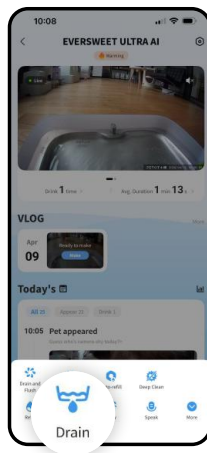

5.3.3 Flush

Tap the "Drain & Flush" button to flush fur and other waste from the water tray into the waste water tank. After flushing, the water tray will automatically be refilled.

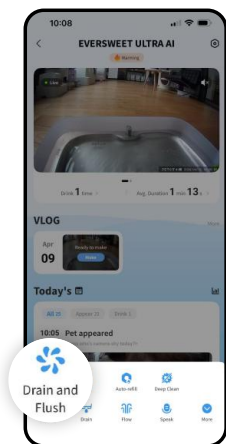

5.3.4 Flow

You can set different water flow modes according to your preference.

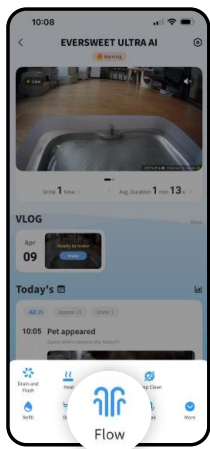

1 Continuous water flow

Water flows continuously from the fountain outlet.

2 Intermittent water flow

Water flows according to the your set (default: 3 minutes on, 3 minutes of).

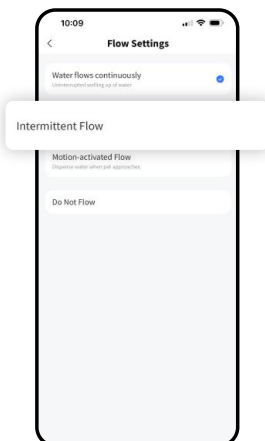
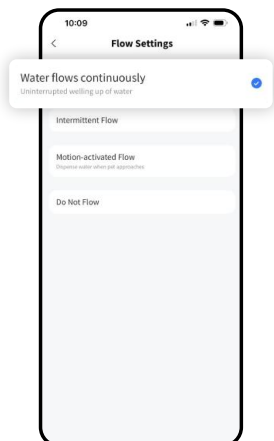

* Note: Interface may vary due to irregular software updates, please refer to the actual one.

③ Motion-activated water flow

When the fountain is in sleep mode and a pet approaches within approximately 10cm (4 inches), it will automatically start flowing.

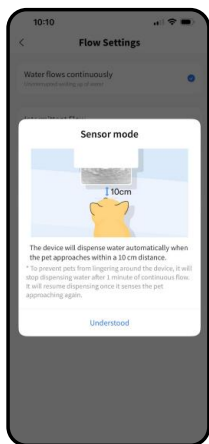

④ No flow

No water flows from the fountain outlet.

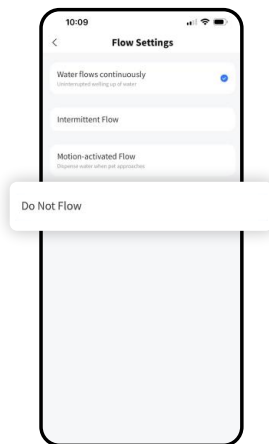

5.3.5 Voice

Press and hold the "Speak" button for real-time interaction with your pet.

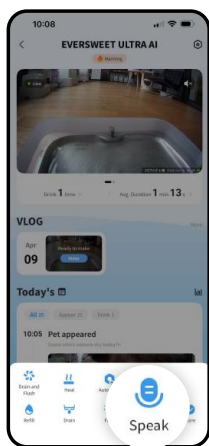

* Note: Interface may vary due to irregular software updates, please refer to the actual one.

5.3.6 Deep Cleaning with Boiling Water

Tap the "Deep Clean" button to start the Boiling Water Cleaning mode. This mode uses boiling water to clean the pump, the FlowLift Module, and the water tray.

⚠ [Caution] Strictly follow the App instructions precisely. To prevent pet burns, ensure your pet stays away from the fountain during the boiling water cleaning process.



① After enabling the mode, the device will first drain the water tray.

② Wait for the FlowLift Module to fully lower, then slowly pour an appropriate amount of boiling water into the water tray (ensure water level does not exceed the MAX line inside the tray).

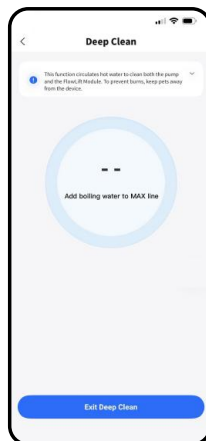
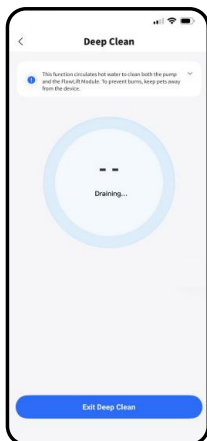

* Note: Interface may vary due to irregular software updates, please refer to the actual one.

③ The device will then automatically begin the boiling water cleaning cycle.

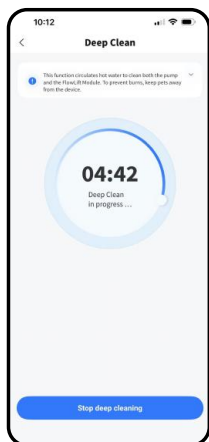

④ This process will take approximately 5 minutes. To prevent pet burns, ensure your pet stays away from the fountain during this process.

⚠️ [Caution]

* The water temperature in the tray is high during the boiling water cleaning cycle. But the water temperature will return to normal approximately 10 minutes after the cleaning cycle finishes.

* If you exit this mode during the cleaning process, the boiling water will be drained into the waste water tank, which may damage the device. Please ensure the water has cooled down before exiting this mode.

5.3.7 Heat

* Note: This function requires the purchase of a Heated Water Tray.

After enabling the heating function, wait approximately 2-3 hours for the water tray to automatically reach the target temperature, turning cool water into warm water and maintaining a constant temperature for 24 hours.

The water temperature in the tray can be adjusted according to your needs, within a range of 20°C to 30°C (68°F to 86°F).

* The actual heating effect and time may vary depending on ambient temperature and water volume.

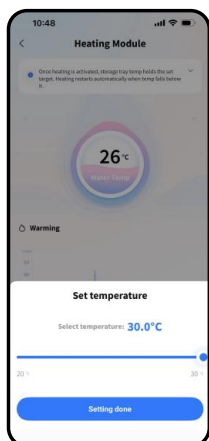

* Note: Interface may vary due to irregular software updates, please refer to the actual one.

5.4 Video Playback

After activating the PETKIT Care+ subscription, tap any video record in the logs to access full video playback, highlight playback, and speed-up playback.

1 Highlight Playback

Tap a video in the logs to view a 4-second accelerated preview version.

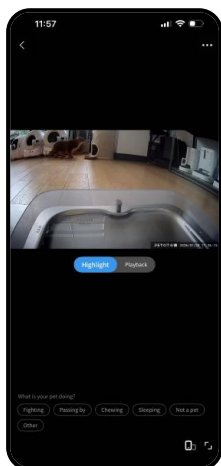

2 Full Video Playback

Switch to the "Playback" tab to view the complete video clip.

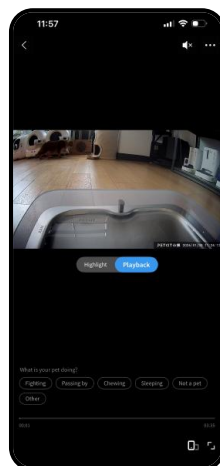

3 Speed-Up Playback

While in full playback mode, tap the ◉◉◉ icon in the top right corner and select the desired playback speed. You can also long-press the center of the video screen to toggle to 2x speed playback.

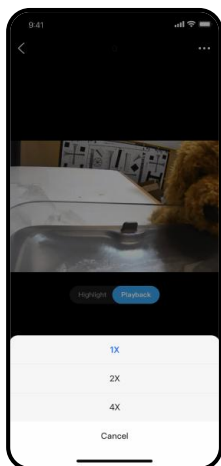

5.5 Deleting Video Clips

You can delete recorded event videos.

❶ **Method 1:** Swipe left to delete the video.

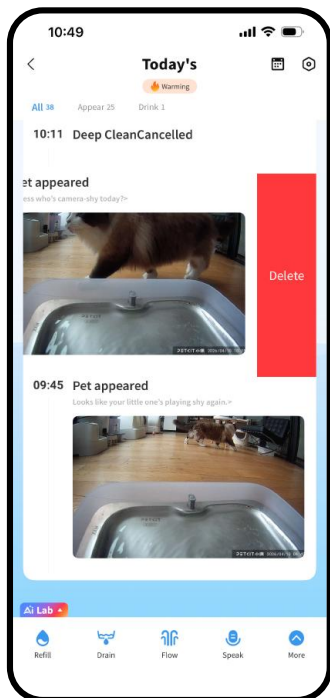

❷ **Method 2:** Tap the video you want to delete, and while in full playback mode, tap the ⋮ icon in the top right corner to delete the video.

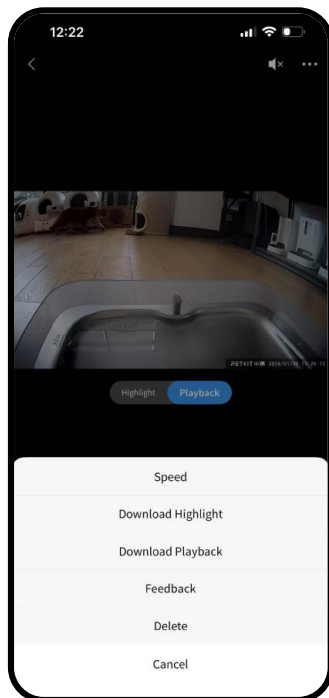

5.6 Privacy Protection

① Camera Permission

You can enable or disable the camera as needed.

⚠️ [Note]

The camera will not record any video when disabled.

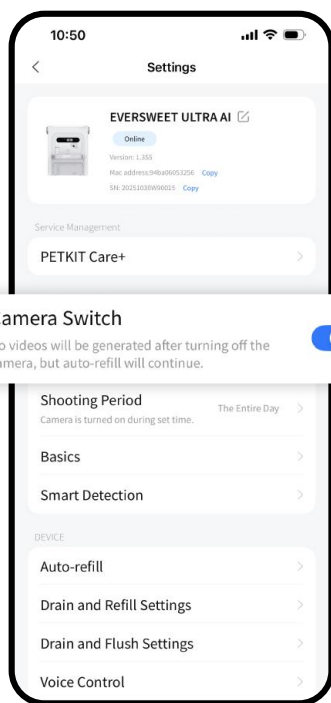

② Custom Camera Detection Period

You can customize the time period during which the camera is active. Outside this period, the camera will automatically turn off.

⚠️ [Note]

During periods when the camera is set to be off, you can temporarily viewing the live feed, but the camera will not record videos.

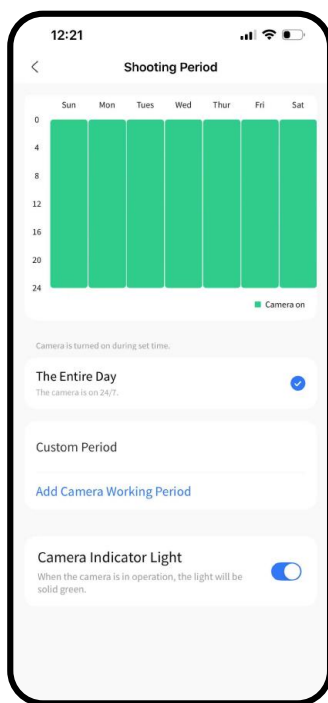

* Note: Interface may vary due to irregular software updates, please refer to the actual one.

3 Smart Detection

You can choose to disable pet detection and drinking detection as needed. When disabled, the camera will not display pet or drinking-related events, nor will it record related videos.

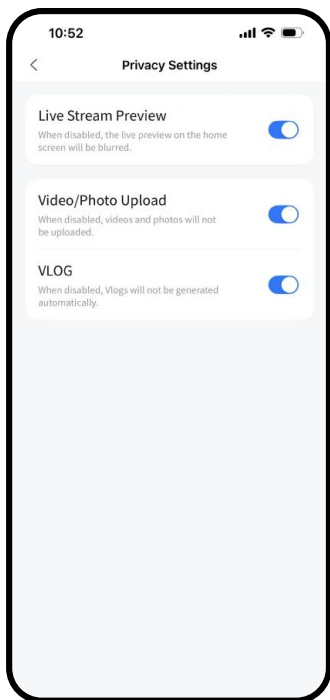

4 Live View Area Protection

When enabled, the live view area will be blurred to protect your privacy.

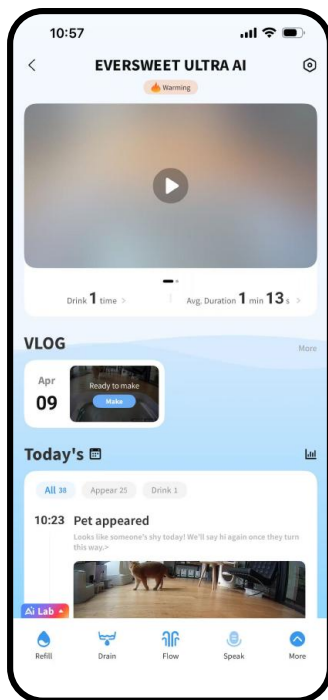

5.7 Additional Notes

① Cloud Storage

Videos are stored for a limited time, and stored videos exceeding the time will be periodically cleared. (e.g., 7-day loop means that videos or pictures from the last 7 days are retained, and content from the eighth day forward is automatically cleared.) All videos can be downloaded, and the downloaded videos can be viewed in the local album of your phone and in the App album.

② PETKIT Care+ service

After subscribing to the PETKIT Care+ service, HD video complete playback and other privileges are available. The details are subject to the page description. PETKIT Care+ service can be transferred to another PETKIT smart devices, which is only once a year. PETKIT Care+ service is a virtual commodity and is non-refundable once purchased.



Click here to view the PETKIT Care+ Service Agreement.

06 CONTROL PANEL & INDICATOR LIGHT

6.1 Indicator Lights and Buttons

Press the “Water Refill Button” to activate automatic filling.
Press and hold it to start filling, and release it to stop filling.

! When pressing and holding the “Water Refill Button”, make sure not to exceed the **MAX** line on the water tray.

Panel Buttons and Indicator Lights

Camera Indicator Light ▼

Solid green: Operating
Off: Not operating

Microphone Indicator Light ▼

Solid green: Operating
Off: Not operating

Wi-Fi Indicator Light ▼

Slow flashing white: Device offline
Fast flashing white: Connecting...
Solid white: Connected

Drain Button ▼

Press: Drain
Press and hold: Wi-Fi pairing

Water Refill Button ▼

Press: Auto filling
Press and hold: Start filling
Release: Stop filling

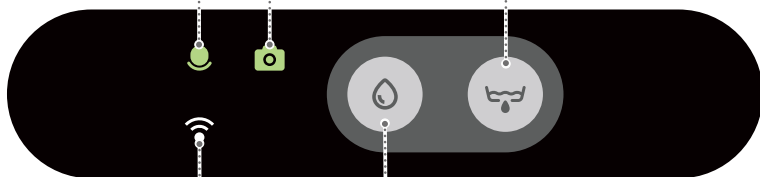

Water Shortage Indicator Light

- ▶ When the red light stays on in the Clean Water Tank, it means the water level is low. Please refill it with purified water promptly.
- ▶ When the red light flashes, it means the tank is empty. Please fill it with purified water immediately.
- ▶ After filling the Clean Water Tank, the light will turn off.

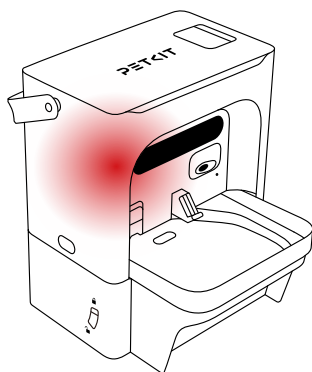

**For filling
methods,
see 3.3**

Waste Water Tank Full Indicator Light

- ▶ When the red light stays on in the Waste Water Tank, it means the tank is full. Please empty it promptly.
- ▶ After emptying the waste water and reinstalling the tank into the Base, the light will turn off.

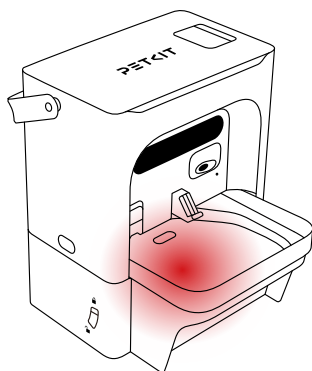

**For emptying
methods,
see 6.2**

6.2 Emptying the Waste Water Tank

❶ Push down the unlock buttons on both sides of the Base, then pull out the Waste Water Tank.

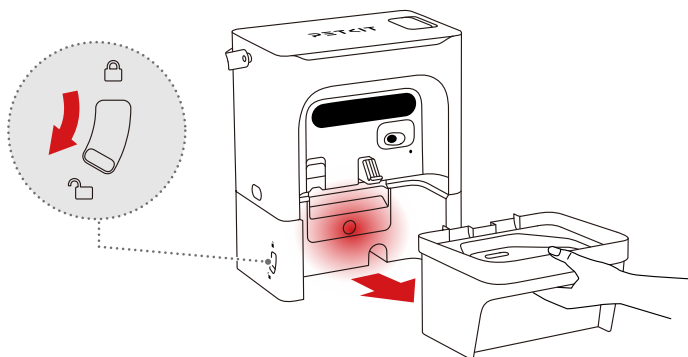

❷ Remove the Water Tray, and pour out the waste water.

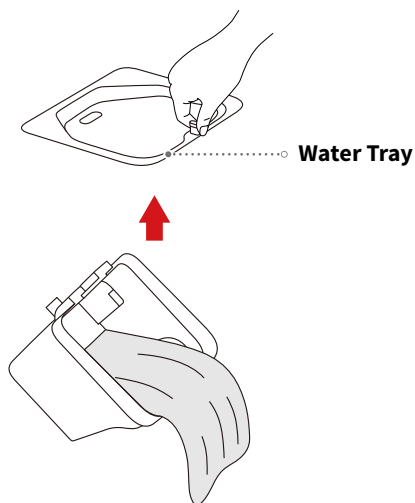

07 VIDEO GUIDE

7.1 Installation and Usage Video



Click to view

7.2 Cleaning and Maintenance Video



Click to view

08 BASIC SPECIFICATIONS

Name	PETKIT EVERSWEET ULTRA AI HEALTH CARE PET WATER FOUNTAIN
Model	P4117
Materials	ABS, 304 stainless steel, PP, PPO
Dimensions	11.41*11.96*13.89 in (290*304*353 mm)
Capacity	Clean Water Tank: 5L; Waste Water Tank: 1.8L
Weight	about 7.71 lb (3.5 kg)
Rated Input	12V === 2A
Connection	2.4 & 5 GHz Wi-Fi, Bluetooth 4.0
Scope of Application	Cats and small-breed dogs

09 TO OUR VALUED USERS

- Thank you for choosing the PETKIT EVERSWEET ULTRA AI HEALTH CARE PET WATER FOUNTAIN.
- Please read the user manual carefully before use. Any installation or usage indicates that you have read and accepted the safety instructions below.
- PETKIT is not responsible for or legally liable for any accidents or injuries resulting from the improper use of the product.
- PETKIT reserves the right to interpretation and revision.

10 SAFETY INSTRUCTIONS

* Failure to follow the safety instructions below may cause product malfunction or other unforeseen damages.

* To ensure the product functions properly, strict tests was conducted before shipment. A small amount of water residue inside the product is normal and does not indicate a defect or prior use. Please use with confidence.

- Install and use the product strictly in accordance with the instructions.
- Pets under 3 months are not recommended for this product.
- Use the product indoors.
- Do not scratch the camera with sharp objects.
- This product is powered by safe low voltage, but pet biting of wires may still cause electric leakage. Please secure and hide the power cord during use to prevent pet biting. If pet biting is observed, stop it immediately.
- Use the original adapter only. Using non-original adapters may damage the device or pose a safety hazard.
- Place the product on a level surface. Do not tip it over, as this may cause malfunction or water spillage.
- Do not immerse or soak the main unit base of this product in water.
- Before use, clean the stainless steel parts of the product.
- Unplug the power cord if the product is not used for an extended period.
- Children should use this product under adult supervision.
- Repairs must be performed under the guidance of professional personnel to prevent accidental injuries.
- If you are going away for an extended period, please make sure to check the remaining water.
- Contact customer service promptly if any issues arise during product use.

Disposal

The European directive 2012 / 19 / CE on Waste Electrical and Electronic Equipment(WEEE), requires that old household electrical appliances must not be disposed in the normal unsorted municipal waste stream. Old appliances must be collected separately in order to optimize the recovery and recycling of the materials they contain and reduce the impact on human health and the environment. The crossed out "wheeled bin" symbol on the product reminds you of your obligation, that when you dispose of the appliance it must be separately collected. Consumers should contact their local authority or retailer for information concerning the correct disposal of their old appliance.

This device complies with part 15 of the FCC Rules. Operation is subject to the following two conditions:

- (1) This device may not cause harmful interference, and ;
- (2) this device must accept any interference received, including interference that may cause undesired operation.

FCC warning:

Any Changes or modifications not expressly approved by the party responsible for compliance could void the user's authority to operate the equipment. Note: This equipment has been tested and found to comply with the limits for a Class B digital device, pursuant to part 15 of the FCC Rules. These limits are designed to provide reasonable protection against harmful interference in a residential installation. This equipment generates uses and can radiate radio frequency energy and, if not installed and used in accordance with the instructions, may cause harmful interference to radio communications. However, there is no guarantee that interference will not occur in a particular installation. If this equipment does cause harmful interference to radio or television reception, which can be determined by turning the equipment off and on, the user is encouraged to try to correct the interference by one or more of the following measures:

- Reorient or relocate the receiving antenna.
- Increase the separation between the equipment and receiver.
- Connect the equipment into an outlet on a circuit different from that to which the receiver is connected.
- Consult the dealer or an experienced radio/TV technician for help.

The device has been evaluated to meet general RF exposure requirement.

This equipment complies with FCC radiation exposure limits set forth for an uncontrolled environment. This equipment should be installed and operated with minimum distance 20cm between the radiator & your body.

IC warning

- English:

This device complies with Industry Canada licence-exempt RSS standard(s). Operation is subject to the following two conditions:

- (1) This device may not cause interference, and
- (2) This device must accept any interference, including interference that may cause undesired operation of the device.

- French:

Le présent appareil est conforme aux CNR d'Industrie Canada applicables aux appareils radio exempts de licence.

L'exploitation est autorisée aux deux conditions suivantes:

- (1) l'appareil ne doit pas produire de brouillage, et
- (2) l'utilisateur de l'appareil doit accepter tout brouillage radioélectrique subi, même si le brouillage est susceptible d'en compromettre le fonctionnement.

